

SmartPower B8X 38 – 400 t

Servo-hydraulic efficiency

world of innovation



EFFICIENT – PRECISE – VERSATILE

The smart basis for your success

The advantages

- » Highly compact servo-hydraulic injection molding machine with outstanding stability
- » High-precision injection units with extensive equipment options
- » Top efficiency with „Drive-on-Demand 2.0“ drive system as standard
- » Additional energy saving through patented KERS energy recovery system
- » User-friendly thanks to Unilog B8X control system with integrated assistance systems
- » Short mold changing time through ergonomically optimized clamping system
- » Conversion into a full production cell possible with WITTMANN auxiliaries and the Wittmann 4.0 “Plug & Produce” integration package
- » Attractive price/performance ratio





SmartPower B8X

The system highlights

- » **Servo drive is standard for the hydraulic system ("Drive-on-Demand 2.0")**
All SmartPower B8X machines are equipped with a combination of fast-responding servo motors with high-performance fixed displacement pumps as standard. The system benefits are extreme dynamism, high speed and precision of the machine movements and minimal energy consumption.
- » **Plasticizing unit – compact, maintenance-friendly**
All SmartPower B8X plasticizing/injection units are pivo-table and designed for easy access. This offers optimal conditions for quick access to the screw. As an option, aggregate versions with servo-electric injection and plasticizing drive are available.
- » **KERS – the optimal energy utilization system**
The patented KERS (Kinetic Energy Recovery System) for injection molding machines transforms the kinetic energy released by deceleration processes into electrical energy. The resulting electrical power is utilized within the machine, e. g. for barrel heating. KERS enables an additional energy consumption cut of up to 5 %.
- » **Well-balanced clamping system protects the molds**
The 4-pillar clamping system, with force transmission via a central pressure pad and two diagonally positioned fast-stroke cylinders, ensures optimal force transmission into the mold and simultaneously a high level of mold protection.
- » **Sensitive mold protection**
Without coming into contact with the tie-bars, the moving platen is guided on linear guides and rotating roller bearings via a sturdy moving carriage with a high load capacity for heavy molds. The minimal rolling friction of the moving platen guide system offers ideal conditions for highly sensitive mold protection and cleanness.

CLAMPING UNIT

A perfectly balanced power pack

- » **Ample space for the mold and for symmetrical force distribution**
Generously dimensioned mold platens and a clamping system with perfect symmetrical force distribution provide an optimal environment for all kinds of injection molding tools, including all types of media connections. [1]
- » **Sensitive and precise**
Within the SmartPower B8X clamping system, the exclusive task of the tie bars is force transmission between the external platens. Without tie bar contact, the moving platen travels on the linear bearings virtually free of friction [2]. In very few steps, the tie bars can be optionally retracted and reset. [3]
- » **Fast movements**
 - The moving platen is driven by two diagonally positioned travel cylinders. [4]
 - Combination of the travel cylinders with a hydraulic differential gear system enables quick movements.
 - The travel cylinders are dimensioned for high opening forces. [4]
- » **Compact design for minimal footprint**
The suction valve placed at the bottom of the pressure cylinder reduces the length of the clamping unit to a minimum. [5]
- » **Maintenance-friendly and easy to clean**
 - Ample use of rigid hydraulic tubes in lieu of hoses reduces potential maintenance requirements. [6]
 - Easy access to the ejector area and platen environment for machine setting [7]

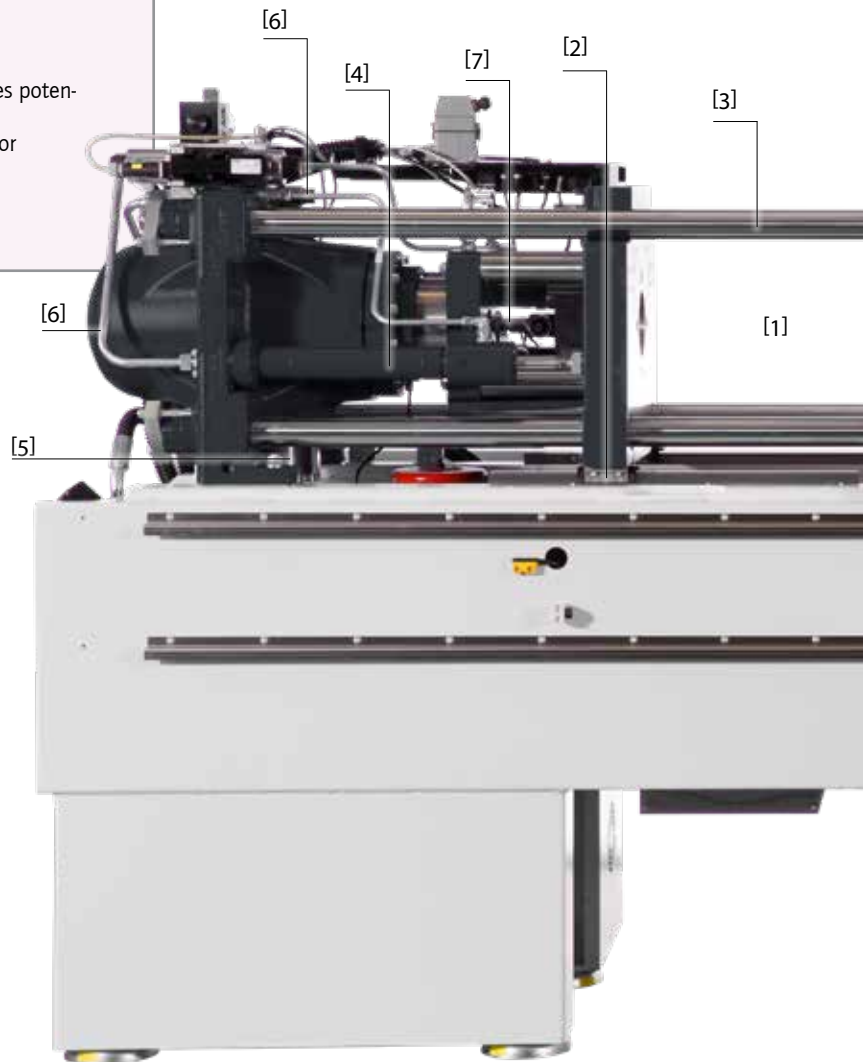

INJECTION UNIT

Versatile precision

Wittmann

- » **Everything designed for series stability**
 - All screws ≥ 25 mm come with a 22:1 L/D ratio.
 - Ultimate repeatability with an optional controlled servo valve
 - Momentum-free nozzle system thanks to axial positioning of the travel cylinders [8]
 - Plasticizing barrels can be fitted to different injection units with identical screw diameter
 - WITTMANN BATTENFELD HiQ software modules (optional) offer sensitive control strategies to compensate external factors such as temperature, moisture, regrind or masterbatch content variations.
- » **Optimal operability and flexibility**
 - Free access to the injection unit for easy material feeding, machine setting and servicing
 - All injection units up to size 3400 are pivotable (for quick screw replacement)
- » **More productivity with electric injection unit (optional)**
 - Highly dynamic control for maximum precision
 - More powerful injection performance
 - Energy-efficient plasticizing parallel to clamping-side movements
 - Start of injection process during clamping force buildup
 - High-resolution absolute value encoder for high-precision control



Anti-wear options

In addition to the premium-quality standard equipment, an extensive range of options is available to provide extra anti-wear and/or anti-corrosion protection. Predefined option packages and a selection matrix facilitate the selection of the right plasticizing unit.

DRIVE TECHNOLOGY

Energy efficiency with "Drive-on-Demand 2.0"



Fast-response, precise, economical

"Drive-on-Demand 2.0" is the innovative combination of a fast-responding, speed-controlled and air-cooled servo motor with a high-quality constant displacement pump. The fast response speed is further enhanced by a booster unit specially developed in-house, which enables a higher clock frequency. This drive unit is only activated as long as required for movements and pressure generation. During cooling times or cycle breaks for parts handling, the servo drive is switched off and consumes no energy. During operation, "Drive-on-Demand 2.0" provides the basis for highly dynamically controlled machine movements and short cycle times.

The "Drive-on-Demand 2.0" system is standard equipment of the SmartPower B8X machine series.

A brake on operating costs

- » The "Drive-on-Demand 2.0" system is standard equipment.
- » "Drive-on-Demand 2.0" lowers energy consumption by up to 35 per cent compared to modern variable displacement pump systems.
- » Additional energy cost cuts through reduction of idle power
- » Lower total expense for cooling, since oil cooling is normally not required
- » Lower maintenance expense through longer preservation of the oil quality due to less thermal load
- » Lower sound emission levels, consequently less investment in sound protection required
- » Easy retrofit of a second servo drive package for parallel movements [1]



INSIDER CONCEPT

"ex works" production cell

Wittmann

The insider concept is an ex-works solution to transform a SmartPower B8X injection molding machine into a fully fledged production cell. In its basic version, the equipment cell integrates a parts handling system, a conveyor belt for parts transport and a protective housing firmly connected with the machine. Additional equipment modules for further processing, quality documentation and packaging are available as options. For the design and configuration of such higher automation levels, the WITTMANN Group places the combined expert knowledge of the entire group at its customers' disposal.

The advantages of insider automation

- » **Material flow systematization**
thanks to a uniform logistics interface for finished parts transfer at the end of the clamping unit, a prerequisite for positioning of several machines in rows
- » **Reduction of production space**
by up to 50 % compared to conventional automation solutions
- » **Minimization of robot cycle times**
through shorter travel paths and immediate parts depositing on conveyor belt
- » **Easy access in spite of integration**
to the mold and the robot thanks to mobility of the conveyor belt integrated in the protective housing
- » **Cost benefits,**
since safety features for all danger areas are already in place and certified ex works
- » **CE mark included**
for every machine with an insider solution. No more costs for individual approval.



CE certified by type examination

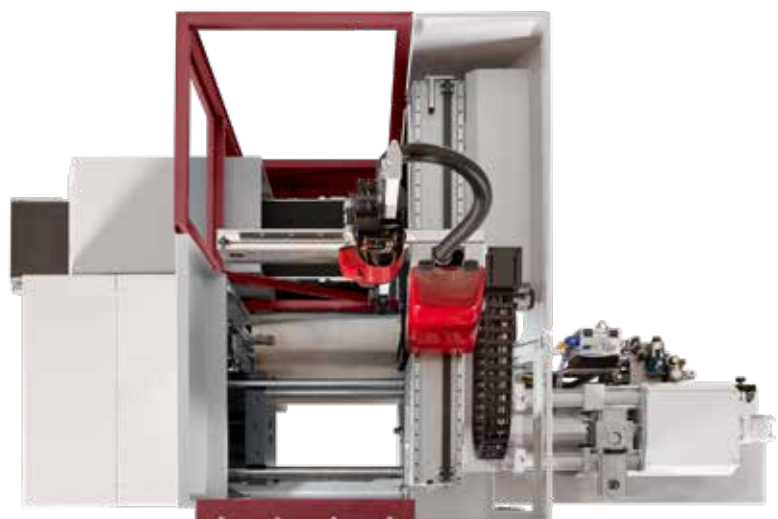

DC TECHNOLOGY

Direct Current as energy source

The WITTMANN Group is the first manufacturer of turnkey systems to offer machines and production cells able to make direct use of energy from renewable sources such as photovoltaics. Using a local DC Microgrid such as supplied by innovergy AG, the injection molding machine, as well as robots and temperature controllers, are powered directly by solar energy via a DC intermediate circuit. In addition, storage batteries can be used, so that any excess energy, for example solar power, can be stored efficiently for effective use later on.



Direct use for more efficiency

- » **No conversion loss:** Direct use of the DC current generated by the photovoltaic system via a DC microgrid reduces the transformation losses caused in conventional power supply with alternating current by the constant changeover from AC to DC and vice versa. The result is a significantly more efficient energy transfer.
- » **Optimal use of the deceleration energy** released by the machine and the WITTMANN robots thanks to KERS (Kinetic Energy Recovery System). The energy recovered from movements can be used not only within the production cell, but also by all consumers integrated in the DC microgrid. A further move to increase efficiency.
- » **Elimination of reactive current transmission:** Reactive power losses can be minimized and energy transmission can be improved by using direct current.

OPTIMIZED PRODUCTION CELL



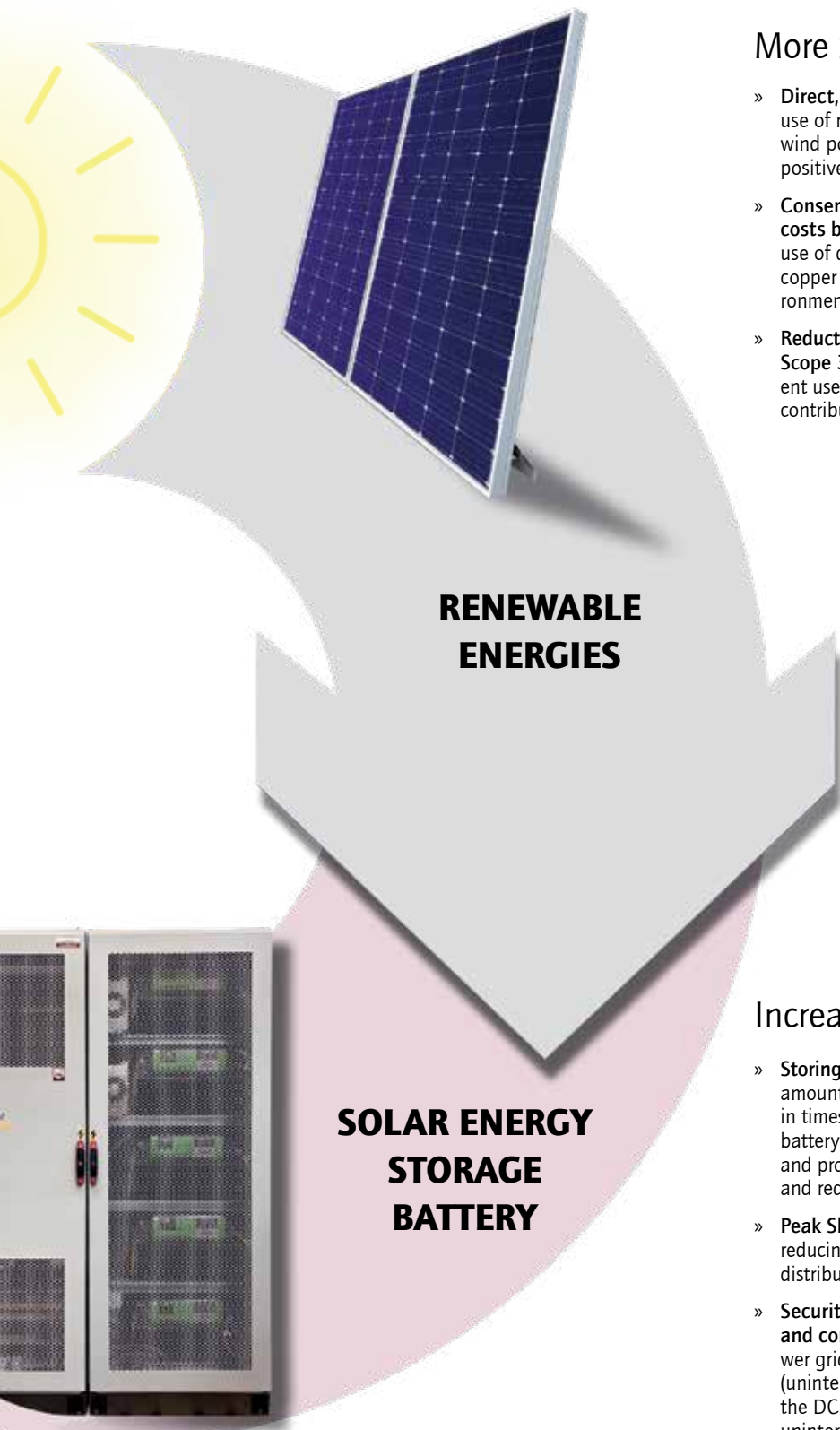

More Sustainability

- » **Direct, efficient use of renewable energy sources:** Direct use of renewable energy sources, such as solar energy or wind power, not only cuts energy costs, but also makes a positive contribution to protecting the environment.
- » **Conservation of resources and reduction of investment costs by up to 50% savings of copper** in a DC grid. The use of direct current enables more efficient utilization of copper cables, thus saving copper and reducing the environmental impact.
- » **Reduction of CO₂ emissions (Greenhouse Gas Protocol Scope 3):** By conversion to renewable energies and efficient use of energy, the CO₂ footprint can be reduced, which contributes to climate protection.

Increasing stability and reducing costs

- » **Storing energy:** Photovoltaic systems produce fluctuating amounts of electric energy. To continue using solar power in times of no sunshine, it makes sense to use a storage battery unit. This increases the internal consumption rate and promotes independence from external power suppliers, and reduces the electricity costs.
- » **Peak Shaving:** Energy storage batteries can contribute to reducing costly load peaks. This leads to more even energy distribution and prevents network overloads.
- » **Security of supply through bridging of power failures and controlled production stop** in cases of prolonged power grid failure through integrated power storage batteries (uninterruptible power supply – UPS is already included in the DC grid). The integration of storage batteries offers uninterruptible power supply and protects the production process against unexpected power failures.

UNILOG B8X

Complex matters simplified

The proven Unilog B8X control system logic with the high-performance hardware is the WITTMANN BATTENFELD solution to make the operation of complex processes easy. To this end, the integrated industrial PC has been equipped with an enlarged intuitive touch-screen control surface. The visualization is the interface to the Windows® 10 IoT operating system, which offers extensive capacity for process control. In addition to the swivel-mounted monitor screen unit, a fixed manual operating panel is installed in the central console.



Unilog B8X Highlights

- » **Operating logic**
with a high degree of self-explanation, similar to modern communication devices
- » **2 major operating principles**
 - Operating/movement functions via tactile keys
 - Process functions on touch screen (access via RFID, key card or key ring)
- » **Process visualization**
via 21.5" touch screen display (full HD), pivoting laterally
- » **New screen functions**
 - Uniform layout for all WITTMANN auxiliaries
 - Recognition of gestures (wiping and zooming by finger movements)
 - Container function – split screen for sub-functions and programs
- » **Status visualization**
uniform signaling system across the entire WITTMANN Group
 - Headline on the screen with colored status bars and pop-up menus
 - AmbiLED display on machine
- » **Operator assistance**
 - QuickSetup: process parameter setting assistant using an integrated material database and a simple query system to retrieve molded part data with machine settings pre-selection
 - Extensive help library integrated

The process in constant view

» **SmartEdit**

SmartEdit is a visual, icon-based cycle sequence programming facility, which enables direct addition of special functions (core pulls, air valves, etc.) based on a standard process via touch operation on the control system's monitor. In this way, a total user-defined sequence can be compiled from a sequence menu. This machine cycle, visualized either horizontally or vertically, can be adjusted simply and flexibly to the process requirements by finger touch with "drag & drop" movements.

The advantages

- Icon visualization ensures clarity.
- Clear events sequence through node diagram
- Alterations without consequences through "dry test runs"
- Theoretical process sequence can be quickly implemented in practice.
- Automatic calculation of the automation sequence based on the actual set-up data set without machine movements

» **SmartScreen**

- Partitioning of screen displays to visualize and operate two different functions simultaneously (e.g. machines and auxiliaries)
- Uniform design of the screen pages within the WITTMANN Group
- Max. 3 containers can be addressed simultaneously for the SmartScreen function.
- Adjustments of set values can be effected directly in the set value profile.

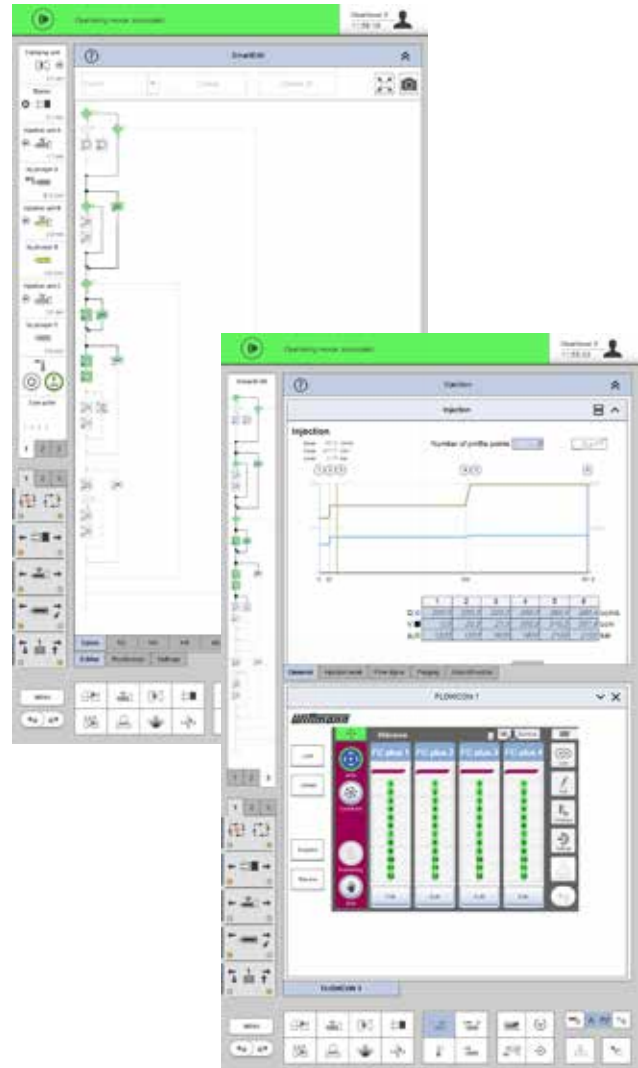

Remote communication

» **QuickLook 4.0**

Production status check via smartphone – simple and comfortable:

- Production data and statuses of all essential auxiliaries in a production cell
- Complete overview of the most important production parameters
- Access to production data, error signals and user-defined data
- The production cell overview offers a clear, simple overview of the production cell's general condition and that of its individual Wittmann 4.0 auxiliaries.

» **Global online service network**

- Web-Service 24/7: direct Internet connection to WITTMANN BATTENFELD service
- Web-Training: efficient staff training by means of the virtual training center

WITTMANN 4.0

Communication in and with production cells

With its communication standard Wittmann 4.0, the WITTMANN Group offers a uniform data transfer platform between injection molding machines and auxiliary equipment from WITTMANN. In case of an auxiliary change, the corresponding visualizations and settings are loaded automatically via an update function, following the principle of "Plug & Produce".

Connection of auxiliaries via Wittmann 4.0

- » **WITTMANN water flow regulator WFC 120, Gravimax blenders and Aton & Drymax dryers**
 - Units directly addressed and controlled via the machine's control system
 - Joint saving of data in the production cell, the machine and in the network via MES
- » **WITTMANN robots with R9 control system**
 - Operation of robots via the machine's monitor screen
 - High-speed communication between machine and robot to synchronize movements
 - Important machine movements can be set via the R9 robot control system.
- » **WITTMANN Tempro plus D temperature controllers**
 - Setting and control of temperatures via the machine's control system possible
 - All functions can be operated either on the unit or via the machine's control system.

Integration in MES system

The integration of machines and complete production cells in an MES system is a prerequisite for an efficient and transparent production facility according to the Industry 4.0 concept. Depending on customers' requirements, small and medium-sized companies as well as global players are offered a compact MES solution based on TEMI+. With the Windows® 10 IoT operating system it is also possible to have selected status information from all connected machines on the production floor shown under Smart-Monitoring on the display screen of every machine.

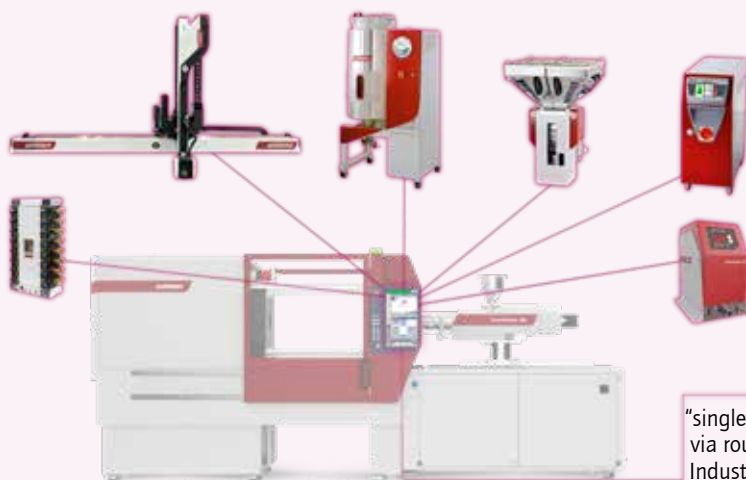

Wittmann 4.0 system

With Wittmann 4.0, a machine and its robots and auxiliaries are transformed into a uniform technical organism, which communicates externally via a specific IP address. Such a "Single point entry" with an integrated internal firewall substantially increases cyber security.

"single point entry"
via router into the
Industry 4.0 world

OPTIONS

Modular and flexible

Wittmann

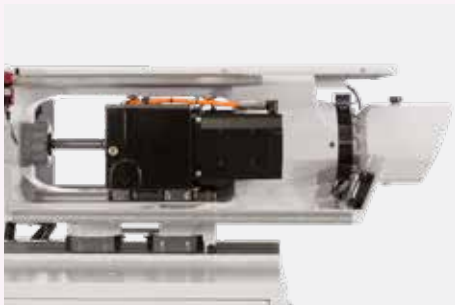
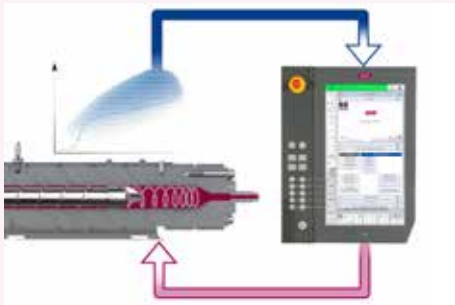

SmartPower B8X

The option highlights

- » **Parallel movements**
Additional pump modules for parallel movements
 - for ejectors and core pulls
 - for higher performance (fast injection)Building-up the nozzle contact pressure during mold closing
- » **HiQ packages**
The HiQ packages offer add-ons for the existing Unilog B8X machine control system software. They provide additional features to give the operator more information about the process, and to facilitate operation of the equipment.
- » **High-performance electric injection unit**
fast-responding, precise, economical
The electric injection unit comes with a dual drive for the injection and dosing functions. A one-piece, torsion-resistant cast frame with linear guides and a central ball screw drive offers the prerequisites for highly dynamic precision in movements. The unit is freely accessible, compact and pivotable.
- » **Fast media connection**
For the ergonomically positioned standard connection points for cooling water, air and core-pull hydraulics, fast coupling plates (individual and system plates) are available as options, as well as power plug systems for the hot-runner heating circuits, temperature and pressure sensors, and coding signals.
- » **WITTMANN auxiliaries**
The comprehensive range of WITTMANN auxiliaries offers the right solutions for all secondary processes of injection molding, including parts handling, material feeding and drying, sprue recycling and mold cooling. Via the optional Wittmann 4.0 integration package, all additional auxiliaries can be integrated into the production cell according to the "Plug and Produce" principle.

APPLICATION TECHNOLOGY B8/B8X

Competence above standard

Clean-room injection molding

For ultra-clean products

Whenever medical components or electronic parts must be produced in an environment free of particles, the SmartPower B8X concept with its easy-to-clean mold space provides a good starting position, which can be adapted to more stringent requirements by optional equipment modules.



Photo: Greiner Bio-One GmbH

Cellmould

Structured foam technology

The production of structured foam parts by targeted addition of pressurized nitrogen dioxide to the plastic melt prior to injection into the mold has been a core competence of WITTMANN BATTENFELD based on in-house R&D for more than 30 years.



Photo: Kunststoff-Institut Lüdenscheid

Airmould

Gas injection

Airmould is the process for gas-assisted injection molding developed by WITTMANN BATTENFELD. Its two variants are the Airmould internal gas pressure process and the external gas pressure process Airmould Contour.



Combimould

Multi-component technology

When two or more plastic materials in different colors or with different attributes must be combined into one part, the SmartPower B8X machines can be equipped with additional injection units in V, L, S or HH configuration and rotary tables with servo drive.



LIM

Liquid Injection Molding

LIM designates the injection molding process to manufacture elastic parts from 2-component LSR (Liquid Silicon Rubber). For processing LSR products, WITTMANN BATTENFELD uses proven modular machines and automation concepts, as well as special plasticizing systems adapted to the viscosity of LSR.



PIM (CIM/MIM)

Powder Injection Molding

Powder injection molding (PIM) is a manufacturing process for series production of components made of metallic or ceramic materials. PIM is the ideal production process for making complex, functional components in large batches and with stringent demands placed on the materials.



SmartPower COMBIMOULD

Highly versatile multi-component injection molding

SmartPower stands for the WITTMANN BATTENFELD injection molding machines with small to medium clamping force sizes (110 to 400 t), featuring a highly efficient servo-hydraulic drive system combined with a compact hydraulic clamping unit and lean injection units in the international standard sizes of 70 to 1670.

Combimould stands for WITTMANN BATTENFELD's multi-component injection molding technology. In this process, a basic part is produced in the first injection molding station, then plastic components in different colors or made of different materials are added in one or several more injection molding stations, all in one cyclical sequence. In this way, various material attributes are combined with each other to create a composite part of better quality in terms of visual attractiveness and functionality. This material combination technology can be used to produce individual parts as well as integrated components joined together by assembly injection molding. Depending on the parts geometry in each case, this requires different process variants.

The SmartPower Combimould in sizes from 110 to 400 t combines the advantages of the generously dimensioned and flexibly adjustable SmartPower clamping unit with the high performance of the EcoPower's all-electric injection units. A great variety of combination options with one or several additional plasticizing/injection aggregates in different configurations makes it possible to create a highly flexible and efficient design tailored to fit all conceivable requirements.





© PLAYMOBIL®



SmartPower Combimould Applications

- » **Back molding**
Simple back molding of two or three plastic layers on a base part or certain areas thereof is the most frequent application. Examples are decorations or anti-wear protection layers.
- » **Assembly injection molding**
By targeted use of the differences in attributes of the plastic materials combined with each other, assemblies can be produced with individual movable or detachable parts. Examples are flexible toy figures, chain links, switch rockers or spout closures with resealing caps.
- » **Hard-soft composites**
An important field of application for assembly injection molding is seal installation. In this process, sealing lips made of silicone or thermoplastic elastomers can be molded directly onto housing bodies or technical parts in a second injection molding step.
- » **Overmolding**
"Overmolding" is a special form of hard-soft combination, where soft, skid-resistant surfaces are created on housing parts or appliance handles with elastomer layers.
- » **Sandwich injection molding – co-injection technology**
This process serves to produce parts with a three-layer structure, consisting of two continuous outer surface layers and a core layer. In terms of process technology, this is achieved by consecutive injection of two materials through the same nozzle into a conventional mold. A foamed or reinforced core component improves the part's mechanical attributes. Costs can be reduced by using regrind and Cellmould foam technology. The surface layers consisting of high-grade materials provide the desired high-quality surface attributes. In the packaging industry, barrier layers can be incorporated in the parts. Reproducible, attractive marbling effects can be achieved by switching several times between two materials of different colors. Depending on the area of application and the requirements to be met by the production equipment, a sandwich adapter plate or a sandwich and interval nozzle is used.

COMBIMOULD PROCESS TECHNOLOGY

Optimally coordinated solution

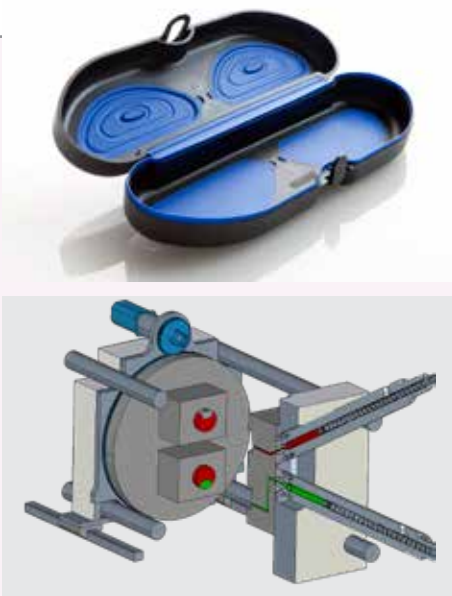

» Rotary unit process

The standard process

Rotary unit technology is the most frequently used Combimould variant. It is used both for overmolding and back molding. Here, the ejector half of an X + X-cavity mold is mounted on a rotary unit. The rotary unit can be designed for alternating rotation movements of +/- 180 degrees (2 stations), 120 degrees (3 stations) or 90 degrees (4 stations).

Following the injection molding process in station 1, the base part produced there is transferred to the overmolding station by opening and rotating the mold half on the ejector side. Parallel to molding the additional components in the subsequent stations, the next base part is produced in station 1. The finished part is removed from the last station.

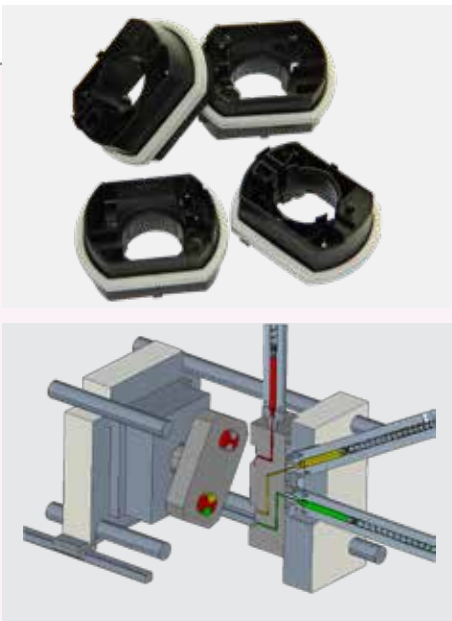

» Index plate process

For complex part design

In index plate technology, the rotation and transfer mechanism is an integral part of the mold. This process must be applied if the second component is to be added on both sides of the part. To this end, the preform must be transferred to a station to receive a modified shape on both sides. This is carried out with the help of an intermediate plate inside the mold, also known as index plate, by which the parts are lifted out of station 1, turned and then re-inserted into station 2. The drive system for the index plate is either integrated in the mold or may be connected to the machine with a servo-electric drive. Rotations of +/- 180 degrees (2 stations), 120 degrees (3 stations) or 90 degrees (4 stations) are possible. The index plate system offers the maximum possible flexibility for molded parts engineering.

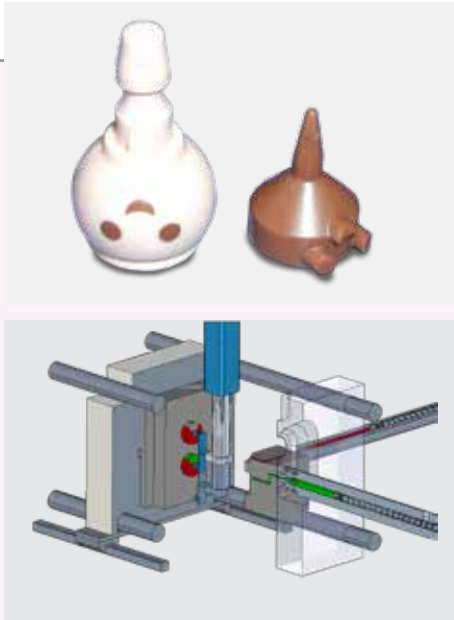

» **Transfer process**

For special cases and small series projects

This process is used as an alternative to the index plate process where the molded part No. 1, due to its geometry, has an insufficient contact area on the index plate for being transported by the index plate between the injection molding stations. Other types of applications are combinations of bulky inserts (such as screwdrivers or knife blades) with plastic components, or a low-cost production alternative for small series.

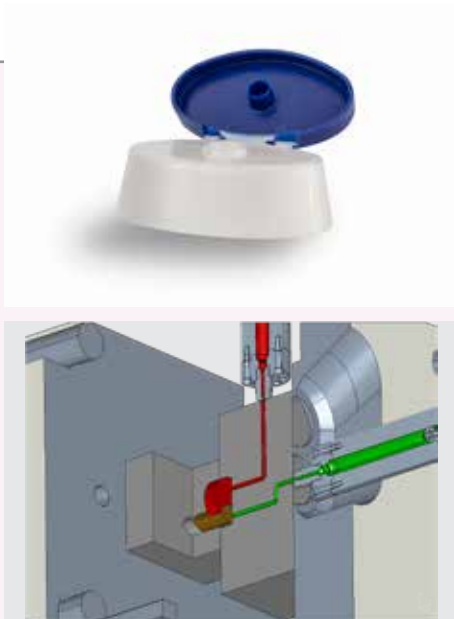

» **Valve gate retraction process**

To add flat components without parts transfer

In valve gate technology, the second component is added without prior mold opening and rotation. The different geometry required inside the cavity is produced by a hydraulic valve gate which, when retracted, provides the space for adding the second component.

In spite of a longer cycle time due to serial production steps, the valve gate process may be of interest economically in mold technology for small numbers of units because of the lower cost of mold technology. In some cases, the compact mold design even allows the use of smaller machines. However, a possible use strongly depends on the design of the molded part and on flat geometries of the additions.

COMBIMOULD INJECTION UNIT

The right combination for every application

In addition to their aggregate in the standard H position (horizontal), SmartPower Combimould machines can be fitted with further aggregates in the following configurations: V (vertical), L (horizontal on the machine's rear side), S (slanted or "piggy-back"), or HH (horizontal, parallel, side by side). In the Combimould version of the SmartPower machines, the horizontal aggregate comes as an all-electric injection unit as standard. The first additional aggregate is controlled via the hydraulic main drive module and thus offers a higher performance level.

A third injection unit can be operated easily via an additional hydraulic module integrated in the oil tank. As an option, all three injection units can also be delivered as electric models.

The Combimould machine concept is designed for unrestricted parallel operation of all injection units with each other. If required, operation of the ejector and the core pulls parallel to the clamping movement is also available as an option.

» V configuration

Injection from above, also into the mold parting line

- Generously dimensioned adjustment range
- Slide device with linear guides
- Simple horizontal adjustment
- V aggregate completely retractable to the rear to provide an absolutely free mold space
- Nozzle position stroke measurement incl. display in the control system

» S configuration

Positioned diagonally above horizontal injection unit

- Compact machine design
- Small footprint
- S and H aggregates movable independently
- Individually adjustable, moment-free nozzle contact force
- Excellent nozzle accessibility

» L configuration

Injection from the non-operator side, even into the mold parting line

- Slide device free on the rear of the fixed platen
- Injection unit supported on linear guides
- Large adjustment range
- Access to the nozzles and to the mold from the rear via large operator safety gate
- Fixed platen free for standard linear robot
- Nozzle position stroke measurement incl. display in control system

» H-H configuration

Two parallel horizontal aggregates

- Both aggregates movable independently of each other
- Good thermal separation of the aggregates
- Compact configuration
- Easy barrel change
- Brief material testing

H-H combination and other configurations and more than 2 injection units upon request



SERVO-ELECTRIC ROTARY UNIT

Fast and precise

Wittmann

For SmartPower Combimould machines, rotary units with a servo-electric drive and ranging from 600 to 1090 mm in diameter are available as an option.

» **Specific technical data**

- Short rotation cycle times thanks to servo-electric drive
- All rotary units are laid out for rotary feed-through of the connected media – for up to 12 media circuits (temperature control, pneumatics, hydraulics) as well as power circuits and sensors.
- All rotary units are available for 2-, 3- and 4-station operation.
- Available for both reversing and round-loop cycles
- Accurate positioning with electronic rotation angle measurement
- End position dampening
- Indexing device
- Rotation parallel to machine and robot movements possible
- Rotation module can be deactivated via control system
- Easy, flexible installation and removal possible

» **Extension options**

- Extended number of media circuits
- Customized ejector positions
- Installation of magnetic mold platens
- Data transfer modules

» **Tie-bar removal device available as standard**

For the insertion of bulky or extra-large molds, one of the tie-bars can be retracted and subsequently returned to its original position in just a few steps.

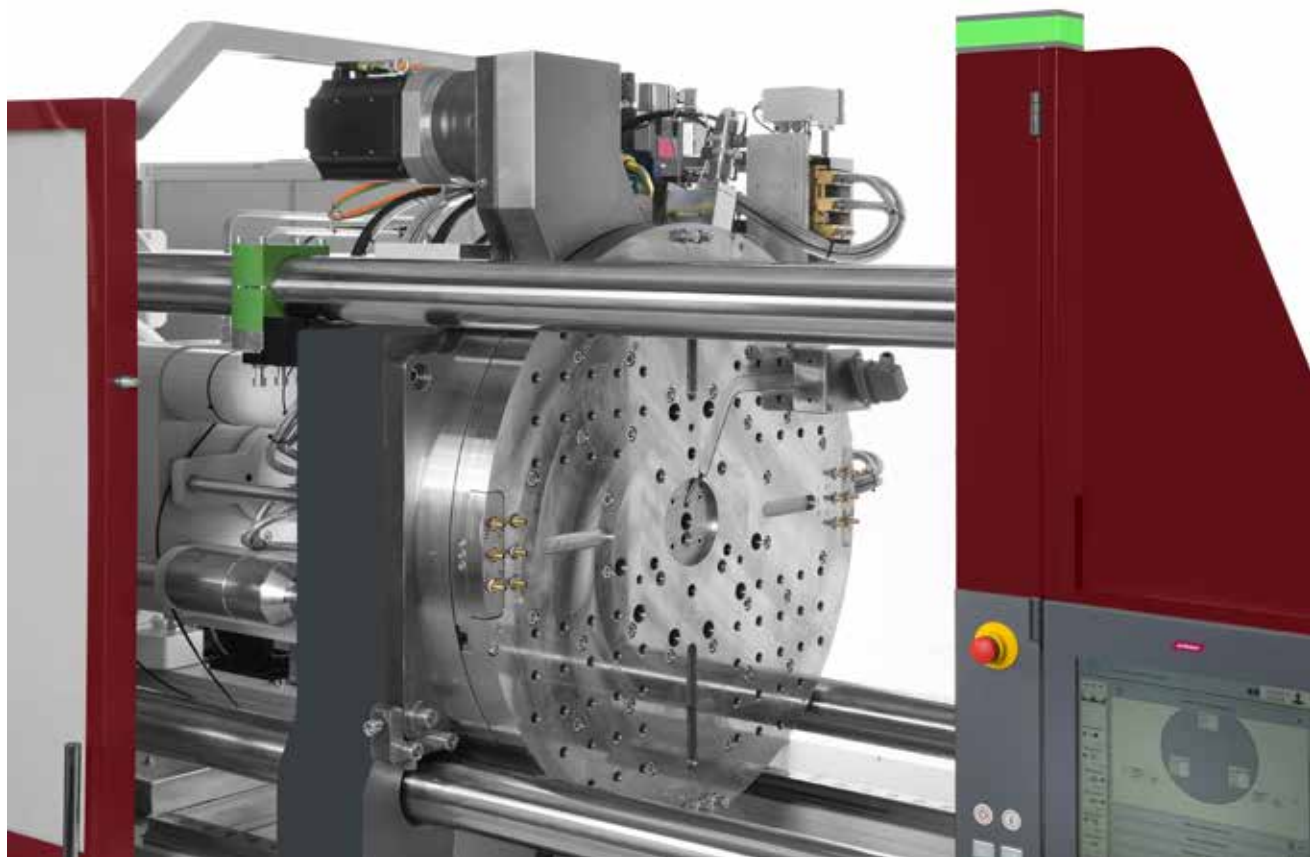

TECHNICAL DATA SmartPower B8X

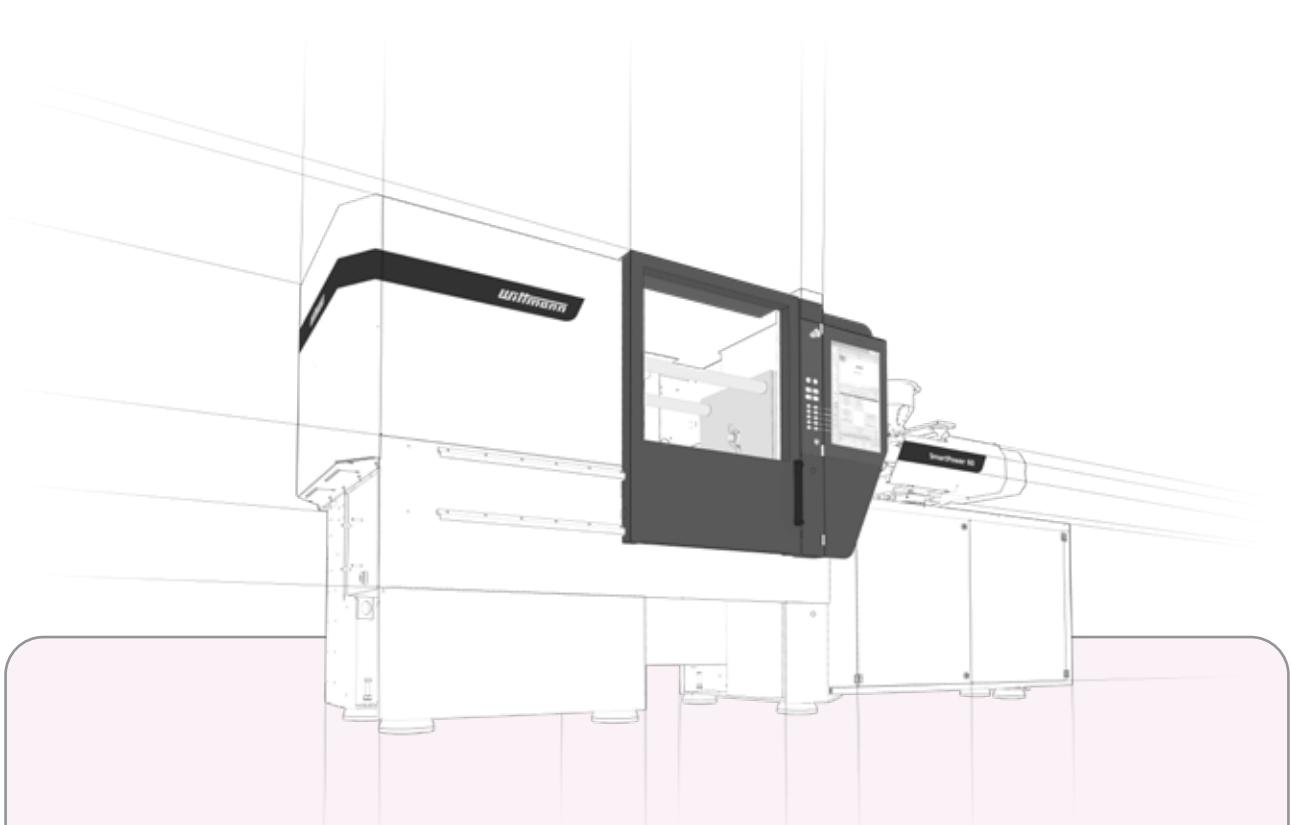

COMBINATIONS OF CLAMPING UNITS/INJECTION UNITS											
Clamping unit	Injection unit										
t	70	130	210	350	525	750	1000	1330	1670	2250	3400
38	•◦	◦◦	•◦								
50	•◦	◦◦	•◦	•							
60	•◦	◦◦	•◦	•							
80	•◦	◦◦	•◦	•◦	◦◦						
90	•◦	◦◦	•◦	•◦	◦◦						
110		◦◦	•◦	•◦	◦◦	◦◦					
120		◦◦	•◦	•◦	◦◦	◦◦					
XL 135				•◦	◦◦	◦◦	•◦				
160					◦◦	◦◦	•◦	•			
180					◦◦	◦◦	•◦	•			
XL 190						◦◦	•◦	◦◦	•◦		
210						◦◦	•◦	◦◦	•◦		
240						◦◦	•◦	◦◦	•◦		
XL 250						◦◦	•◦	◦◦	•◦	•	
300						◦◦	•◦	◦◦	•◦	•	
350						◦◦	•◦	◦◦	•◦	•	
400							◦◦	◦◦	•◦	•	•

• SmartPower B8X ◦ SmartPower B8X with e-unit (Option)

Material	Factor
ABS	0.88
CA	1.02
CAB	0.97
PA	0.91
PC	0.97
PE	0.71
PMMA	0.94
POM	1.15
PP	0.73

Material	Factor
PP + 20 % Talc	0.85
PP + 40 % Talc	0.98
PP + 20 % GF	0.85
PS	0.91
PVC hard	1.12
PVC soft	1.02
SAN	0.88
SB	0.88

The maximum shotweights (g) are calculated by multiplying the theoretical shot volume (cm³) by the above factor.

DATA SmartPower B8X COMBIMOULD



SmartPower B8X Combimould 110 / 120

Injection unit	130 H	210 H	350 H	525 H	750 H
70	V-L-S	V-L-S	V-L-S	V-L-S	V-L-S
130	V-L-S	V-L-S	V-L-S	V-L-S	V-L-S
210	V-L-S	V-L-S	V-L-S	V-L-S	V-L-S

SmartPower B8X Combimould 160 / 180

Injection unit	210 H	350 H	525 H	750 H	1000 H
130	V-L-S	V-L-S	V-L-S	V-L-S	V-L-S
210	V-L-S	V-L-S	V-L-S	V-L-S	V-L-S
350	V-L-S	V-L-S	V-L-S	V-L-S	V-L-S

SmartPower B8X Combimould 210 / 240

Injection unit	350 H	525 H	750 H	1000 H	1330 H
130	V-L-S	V-L-S	V-L-S	V-L-S	V-L-S
210	V-L-S	V-L-S </td <td>V-L-S</td> <td>V-L-S</td> <td>V-L-S</td>	V-L-S	V-L-S	V-L-S
350	V-L-S	V-L-S	V-L-S	V-L-S	V-L-S
525	V-L-S	V-L-S	V-L-S	V-L-S	V-L-S

SmartPower B8X Combimould 300 / 350 / 400

Injection unit	525 H	750 H	1000 H	1330 H	1670 H
130	V-L-S	V-L-S	V-L-S	V-L-S	V-L-S
210	V-L-S	V-L-S	V-L-S	V-L-S	V-L-S
350	V-L-S	V-L-S	V-L-S	V-L-S	V-L-S
525	V-L-S	V-L-S	V-L-S	V-L-S	V-L-S
750	V-L-S	V-L-S	V-L-S	V-L-S	V-L-S

H	horizontal	V	vertical	S	diagonal	L	horizontal from the non-operator side
----------	------------	----------	----------	----------	----------	----------	---------------------------------------

Other combinations and B and HH arrangements available on request

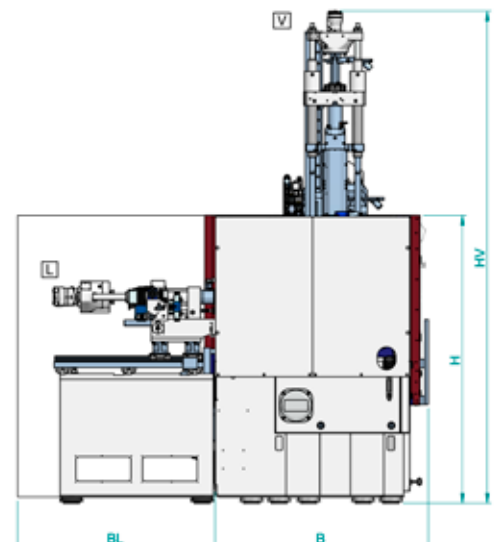
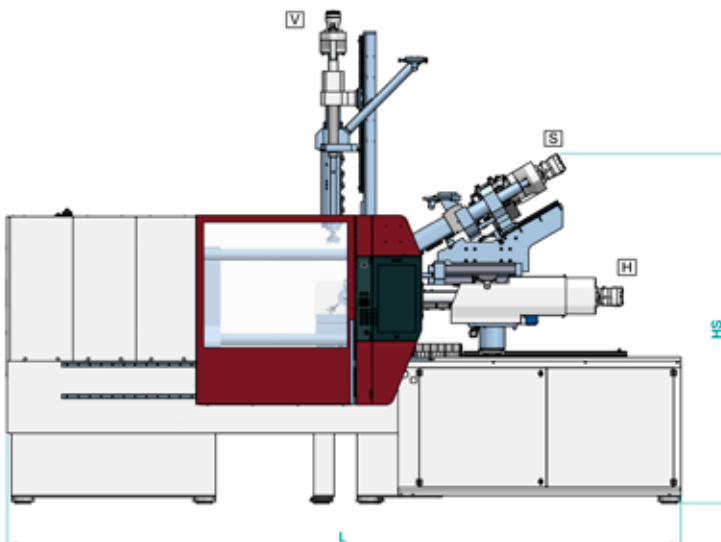

Bonding of hard-soft material combinations

	TPE based on polyamide	TPE-polyester-elastomers	TPE based on polyolefin	TPE based on styrene	TPE thermoplastic polyurethane	TPE types with modified adhesive properties
ABS	■	□	■	■	▲	△
ASA		▲			▲	
CA						▲
PA 6	△		■	■	▲	△
PA 6.6	△			■	▲	△
PA-Blend	△		□	□		△
PBTP	■	□		▲	■	△
PC	■	□	■	□	▲	△
PC/ABS	■	□	■	□	▲	△
PC/PBT	■	□	■	□	▲	△
PC/PET	■	□	■	□	▲	△
PE	■		□	□		▲
PETP	■					▲
PMMA				□	□	▲
POM	■				▲	▲
PP	■	■		▲		△
PPO	■					▲
PS	■	■	■			△
PAN	■				▲	△

Due to the great variety of TPE types, the bonding strength must be checked in each individual case.

The bonding strength also depends on the part geometry, process conditions and processes involved.

Bonding of thermoplastic materials in multi-component injection molding

	ABS	ASA	CA	PA 6	PA 6.6	PA-Blend	PBTP	PC	PC/ABS	PC/PBT	PC/PET	PE	PETP	PMMA	POM	PP	PPO	PS	SAN	TPE/TPU
ABS	△	▲	▲	▲	▲		▲	▲	▲	▲	▲	□	▲	▲	■		■		□	□
ASA	▲	△	▲		▲		▲	▲	▲	▲	▲	■	▲	▲	■	■	■	■	▲	□
CA	▲	▲	△				▲					■			■	■	■			
PA 6	▲			△	△	▲	▲	□	▲	▲	▲	□			■	□	■	■		□
PA 6.6	▲	▲		△	△	▲	□		▲	▲	▲	□			■	□	■	■		□
PA-Blend				▲	▲	△									□	□	■			□
PBTP	▲	▲	▲	▲	□		△	▲	▲	▲	▲	□	▲	□	□	□		□	▲	□
PC	▲	▲			▲		▲	△	▲	▲	▲	■	▲		□	■		■	▲	□
PC/ABS	▲	▲		▲	▲		▲	▲	△	▲		■			□	■		■		□
PC/PBT	▲	▲		▲	▲		▲	▲	△	▲	▲	■	▲	▲	□	■		■		□
PC/PET	▲	▲		▲	▲		▲	▲	▲	△	▲	■	▲	▲	□	■		■		□
PE	□	■	■	□	□		□					△				▲			□	▲
PETP	▲	▲					▲	▲		▲	▲	■	△							□
PMMA	▲	▲					□			▲	▲	■		△		■	■	■	▲	□
POM	□	■	■	■	■	□	□	□	□	□	□	■			△					□
PP		■	■	□	□	□	□	■	■	■	■				■		△	□		
PPO	■	■	■	■	■	■									■		□	△		□
PS	■	■		■	■		□	■	■	■	■				■			▲	△	□
SAN	□	▲	▲				▲	▲	□	□	□	□		▲			■	□	△	▲
TPE/TPU	□	□		□	□	□	□	□	□	□	□	▲	□	□	□	△	□	□	▲	△

In some cases, particularly where modified materials are involved, tests must be carried out to check the bonding strength.

- limited bonding
- no bonding
- ▲ good bonding
- △ excellent bonding

Base machine
Drop - voltage 230/400 V/3p+N-TN/TT, 50 Hz
Painting RAL 7047 tele grey / RAL 7016 anthracite / RAL 3004 crimson
Air cooling system for drive unit, water cooling for feeding zone and oil cooler with solenoid valve
One-piece base frame with 3 disposal directions
Injection moulding machine according to machinery directive 2006/42/EG incl. declaration of conformity and CE-marking
Test-run with hydraulic oil HLP32 zinc free according to DIN 51524 T2 / purity level 17/15/12 according to ISO 4406 (Attention: oil is not included in delivery), lubricants according to H2-quality
Printed operating manual incl. user manual on USB flash drive in any EU language acc. to definition of country
Injection molding machine according to machinery directive 2006/42/EG Levelling pads
Hydraulics
Drive unit S0 with speed controlled servo motor for hydraulic pump to increase the energy efficiency
Hydraulics with oil cooler controlled in water inlet of cooling, oil level monitoring, oil filtration with electrical clogging indicator
Oil preheating of hydraulic drive
Clamping unit
Clamping force and closing and opening forces adjustable
Mold safety program
Moving platen supported by positioned linear guides
Mold platen according to EUROMAP 2, clamping surface metallic bright, rest painted
Fixing holes for robot on fixed platen as per EUROMAP 18
Hydraulic multi stroke ejector
Clamping cylinder plunger induction hardened & hard chrome-plated, ejector piston hard chrome-plated, position sensor with linear potentiometer
Injection unit
Hydraulic screw drive
Injection axis/nozzle carriage - injection, holding and back pressure controlled with defined nozzle contact pressure
Plasticizing unit AK+ for thermoset processing, 3-zone universal screw, flow-optimized check valve, heater bands up to 350 °C with heat insulation of feed zone grooving
Thermocouple failure monitor
Maximum temperature supervision
Plug-in ceramic heater bands
Temperature control of feed throat integrated
Swivelling injection unit
Linear guides in standard design, position sensor with linear potentiometer
Selectable barrel stand-by temperature
Decompression before and/or after metering
Physical units - bar, ccm, mm/s etc.
Screw protection
Auxiliary screw speed indication
Linear interpolation of holding pressure set values
Bar chart for barrel temperature with set value and actual value display
Selectable injection pressure limitation
Changeover from injection to holding pressure depending on stroke, time and pressure
Open nozzle R35 split
Splash guard and barrel covering in standard execution according to EN ISO 20430, L/D 22 protected via limit switch
Material hopper 6 litres (MH206) for automatical material feed, sliding device with shut-off function for material with sliding guide

Safety gate
Covering injection side - maintenance door screwed together
Safety gate in standard execution, acrylic glass clear / frame RAL 3004 crimson
Safety gate at operator and non-operator side manually operated
Monitored safety gate electrically controlled according to CE on front and rear side
Maintenance-free safety gate locked by electromagnet
Safety gate free for mold change and handling by robot
Electrics
Control zone for nozzle heater band 230 V
AmbiLED-status indicator
Switch cabinet cooling - circulation fan for environment temp. to 30 °C
Emergency stop switch button
USB connection on control unit for printer or network
1 Ethernet interface (switch cabinet)
Control system
Control system Unilog B8X - 21,5" multi-touch screen (full HD)
Control panel with selectable haptic keys
Software for operating hours counter
Closing/Opening - 5 profile steps
Ejection forward/back - 3 profile steps
Nozzle forward/back - 3 profile steps
Injection/Holding pressure - 10 profile steps
Screw speed/Back pressure - 6 profile steps
Parts counter with good/bad part evaluation
Purging program through open mold
Stroke zero offset settings
Start-up program
Switchover to holding pressure MASTER/SLAVE by injection time, screw stroke/injection volume and injection pressure
Self-teaching temperature controller
Display of temperature inside electrical cabinet
Seven-day timer
Access authorization via RFID system (1 x check card IT-level-15, 1 x token customer level-30 and 1 x token customer service level-20 incl. in delivery)
Freely configurable status bar
Physical, process-related units
Automatic dimming
Logbook with filter function
User programming system (APS)
Userpage
Note pad function
Cycle time analysis
Hardcopy function
Internal data storage via USB connection or network
Online language selection
Online selection of imperial or metric units
Time monitoring
Basic Quality Monitoring (1 freely configurable network connection, quality table with 1000 storage depth, events protocol (logbook) for 1000 events, actual value graphics with 5 curves, 1 envelope curves monitoring)
Injection integral supervision, Metering integral supervision
Alarm message via e-mail
SmartEdit - sequence editor
QuickSetup - assistance program for initial parameter setting
Energy consumption monitoring for motors and heating
2 outputs, freely programmable

Base machine

Special voltage
Handling package with open machine safety gate on non operator side
Parts hopper w/o separation of sprues, good/bad parts or photoelectric ejection check
Non-standard mold height/opening stroke
Machine frame increased
Special paint

Hydraulics/Pneumatics

Drive unit with speed controlled servo motor for hydraulic pump incl. additional pump for core pull movement, parallel ejection, fast injection and/or hydraulic mold shut-off nozzle
Injection parallel to clamp force build-up ¹⁾
Raw filter in water inlet of cooling incl. adapter with ball valve for oil maintenance on oil tank
Hydraulic core pull for clamping plate, interface according to EUROMAP 13, incl. or without core pull pressure release
Pneum. core pull on clamping plate/nozzle plate
Hydraulic, pneumatic manifolds for one mold shut-off nozzle or more
Air valves on nozzle plate/clamping plate
Compressed air pressure maintenance unit incl. 1 or more way pressure regulation incl. directional exhaust valve with blocking function

Clamping unit

Support for middle plate or heavy molds
Mold platen according to SPI, JIS, T-slots
Mold platen incl. cooling channels
Manuel tie-bar retract device
Hydraulic ejector in reinforced execution
Ejector pressure/speed controlled by P/Q servo valve
Unscrewing device in lieu of ejector
Double check valve to keep ejector in end-position
Ejector cross according to EUROMAP/SPI, JIS
Mechanical or pneumatic ejector coupling
Ejector platen safety
Mechanical mold safety mechanism

Injection unit

Screw drive by A.C. servo-motor for parallel recovery during cycle, Injection axis via servo motor and def. hydraulic nozzle contact pressure ¹⁾
Injection, holding and back pressure controlled via servo valve with defined nozzle contact pressure
Linear guides in standard design, position sensor with non-contact stroke transducer
Splash guard and barrel covering in standard execution according to EN 201, L/D 22 protected via transponder switch
High torque hydraulic screw drive
Check valve to hold screw in position after end of dosing
Corrosion resistance injection unit
Plasticizing unit AK++ in high wear and corrosion resistant execution
Plasticizing unit AKCN in wear and corrosion resistant execution, for processing PMMA and ABS and PC
Barrier section, screw with mixing section
Ball type screw tip
Melt pressure transducer, melt temperature sensor
Heater bands up to 450 °C
Plasticizing unit in special execution for LIM, MIM, CIM, PVC, Cellmould
Open nozzles in special execution
Needle type shut-off nozzle operated pneumatically
Pneumatic cross-bolt type shut-off nozzle
Open Airmould nozzle, pressure controlled

Barrel covering and splash guard in special execution
Vacuum package incl. vacuum pump
Material hopper in special execution
Hopper magnet

Safety gate

Safety gate clamping side, rear side and/or operator side elevated, lowered or extended
Insider package WITTMANN rear side incl. conveyor belt
Front side gate safety system for manual part removal incl. clearance of ejector

Cooling and conditioning

Cooling water distributor with/without blow-off valve
Solenoid valve for cooling water distributor
Machine cooling by T-piece in inlet pipe
Filter back flushable/water pressure supervision in inlet pipe
Distributor block on nozzle plate/clamping plate
WFC 120 integrated into control system

Electrics

Emergency stop switch button in control panel and on non operator side
Temperature control zones for hot runner
Acoustic element integrated in signal lamp
Socket combination
Additional fan in electric switch cabinet for increased environment temperature
Cabinet air conditioner
Interface for robot, conveyor belt, TCU, dosing unit, Airmould, mold surveillance, production data logging system, RJG eDart, Priamus BlueLine, danger zone boundary, ejection in mold middle plate, brushing device, relay signals, vacuum pump
Integration package Wittmann 4.0 BASE consisting of: Router for integration respectively protection of injection moulding cell in production network

Control system

Cavity pressure switchover
BNC sockets for injection process analysis
Expert Quality Monitoring (4 freely configurable network connections, quality table with 10000 storage depth, events protocol (logbook) for 10000 events, actual value graphic with 16 curves, 4 envelope curves monitoring, SPC charts, trend diagrams)
Mold identification
Special programs on customer request
HiQ Packages
Software Tandemmould, multiple data sets
Energy consumption analysis
Clamp force supervision
Injection compression and venting program
Initiation of next cycle by closing safety gate
Special program ejector ejection of cold slug
Additional output card/input card, freely programmable
Integration package Wittmann 4.0

Additional equipment

Plinth for robot
Tool kit
Lighting in mold space
Mold clamping systems in mechanical, electrical or hydraulic execution
Integration package (robot, feeder, dosing unit, TCU, mold integration)
Wittmann Battenfeld web service during warranty period free of charge
Remote control package

¹⁾ only in combination with the e-injection unit (option)

The Wittmann logo is located in the bottom right corner of the page. It consists of the word "Wittmann" in a white, italicized, sans-serif font, set against a dark red, rounded rectangular background.

WITTMANN BATTENFELD GmbH

Wiener Neustädter Strasse 81

2542 Kottlingbrunn | Austria

Tel.: +43 2252 404-0

info@wittmann-group.com

www.wittmann-group.com